

# 15-440: Distributed Systems

## Recitation 11

School of Computer Science  
Carnegie Mellon University, Qatar  
Fall 2017

*November 09<sup>th</sup>, 2016*

# 1 Intended Learning Outcome (ILO)

The ILO of this recitation is:

- Apply MapReduce to a real problem.

# 2 Objectives

- Understand the MapReduce data flow at a high level.
- Develop and run a simple MapReduce program.

# 3 High-Level MapReduce Data-Flow

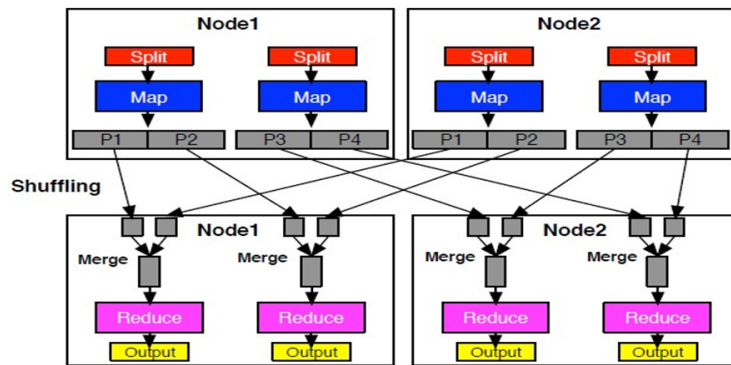

## 4 The WordCount Problem

Write a MapReduce application, referred to as WordCount, that computes the occurrence frequency of each word in text files. After you write your application, follow the following steps:

1. Create a folder for the .class files of your application using the following command:

```
$ mkdir WordCount_Classes
```

2. Compile your WordCount program using the following command:

```
$ javac -classpath $HADOOP_HOME/hadoop-0.20.2-core.jar  
-d WordCount_Classes WordCount.java
```

*where WordCount.java is the program's name and that HADOOP\_HOME is the root of the Hadoop installation.*

3. Create the jar file required by Hadoop to run your application using the following command:

```
$ jar -cvf WordCount.jar -C WordCount_Classes/ .
```

*where "-C WordCount\_Classes" part of this command directs the Jar tool to go to the WordCount\_Classes directory, and the "." following C WordCount\_Classes/ directs the Jar tool to archive all the contents of in the current directory.*

4. Create two simple sample text files, file01 and file02. For instance you can have them as follows:

- **file01:** Welcome to MapReduce
- **file02:** Welcome to MapReduce in 15440

5. Create an input directory in HDFS using the following command:

```
$ hadoop dfs -mkdir /user/hadoop/wordcount/input
```

6. Copy **file01** and **file02** to your HDFS input directory using the following commands:

```
$ hadoop dfs -copyFromLocal file01 /user/hadoop/wordcount/input  
$ hadoop dfs -copyFromLocal file02 /user/hadoop/wordcount/input
```

7. Check that **file01** and **file02** now exist at `user/hadoop/wordcount/input` using the following command:

```
$ hadoop dfs -ls /user/hadoop/wordcount/input
```

8. Run your WordCount application using the following command:

```
$ hadoop jar WordCount.jar WordCount  
/user/hadoop/wordcount/input /user/hadoop/wordcount/output
```

9. Use the MapReduce Web UI to view information about your job

```
http://andrewID-n01.qatar.cmu.local:50030/jobtracker.jsp
```